

# ANALYSES OF TEMPERATURE AND PRESSURE CONDITION IN CI ENGINE'S EXHAUST PIPE IN LIGHT OF APPLICATION NO<sub>x</sub> SENSOR TO DETERMINE OF CATALYTIC CONVERTER EFFICIENCY

**Marcin Rychter**

*Motor Transport Institute  
Diagnostic and Servicing Process Department  
Jagiellońska Street 80, 03-301 Warsaw, Poland  
tel.: +48 22 8141235, fax: +48 22 8110 06  
e-mail: marcin.rychter@its.waw.plrychter@poczta.fm*

## **Abstract**

*The development of a catalytic converter required an analysis of selected physical parameters of the supports. This resulted from the necessity to assume given parameters of the supports applied in the tests in exhaust gas environment in the CI engines. An analysis of ionic conductors which constitute the basic solution in voltage sensors providing signals through NO<sub>x</sub> electrocatalysis. The aim of this paper is to determine the basis for the monitoring of catalytic converters in compression ignition engines by the emission level of a selected exhaust gas component as a diagnostic signal. The emission of NO<sub>x</sub> has been taken as the basis. This required the development of a specialized system allowing the reduction of NO<sub>x</sub> and obtaining of a diagnostic signal reflecting the level of the said reduction. This paper includes some results of testing and possibilities monitoring of prototype catalytic converter on the test bed. On the basis of the performed examinations and obtained test results the following conclusions can be drawn: the analysis of the NO<sub>x</sub> concentrations in exhaust gas from the compression-ignition engine can be based on the indications of the voltage probes with the modified electrodes of the oxygen pump, the application of the reduction conditions in the voltage probes using the nitrogen oxides reduction by the electro-catalytic way depends on the exhaust gas parameters, the values of which change depending on the rotational crankshaft speed and engine load, and for this reason obtaining the diagnostic signal for the whole engine operation range is impossible, the control of the correctness of the catalyst operation regarding the nitrogen oxides reduction can be realised for the defined operating parameters of the tested engine, for phases VIII and X of the ESC test the reheating the test probe installed before the catalyst was unnecessary, owing to the high exhaust gas temperature (737–759°C).*

**Keywords:** *transport, internal combustion engine, catalytic converter, diagnostic system*

## **1. Introduction**

The OBD system (On Board Diagnostic system; known in the United States as the OBD II system and in Europe as the EOBD one) is a set of diagnostic tests and calculation and decisive procedures which are performed in a real time and are intended as a measure for evaluation of the emission efficiency and the efficiency of elements responsible for the passive and active safety of a vehicle. The OBD system is an integral part of the vehicle connected with the engine control system. Nowadays the investigation on the on board diagnostic systems in their different applications is one of the basic problems that the OBD method is concerned with. The implementation of the investigation method for the OBD system efficiency is one of the main questions of the matter in hand.

After the obligation of using the OBD system was introduced the evaluation of the technical state of vehicles (especially their environmental and safety parameters) during their whole operation time, which previously the service stations staff and vehicle users were interested in, has become a legally required task that the manufacturers of vehicles have to deal with. The manufacturer is responsible for the complete life cycle of vehicles i.e. from the production throughout the operation up to their scrapping, however, the cycle should be closed and

environment friendly (using materials of the scrapped vehicles for the production of the new ones - recycling).

In order to satisfy such postulates the realization of the implemented diagnostic procedures during the real operation of vehicles and in the possible shortest time is necessary. Thus the evaluation of the operating efficiency OBDE (On Board Diagnostic Efficiency) of the OBD system is also necessary.

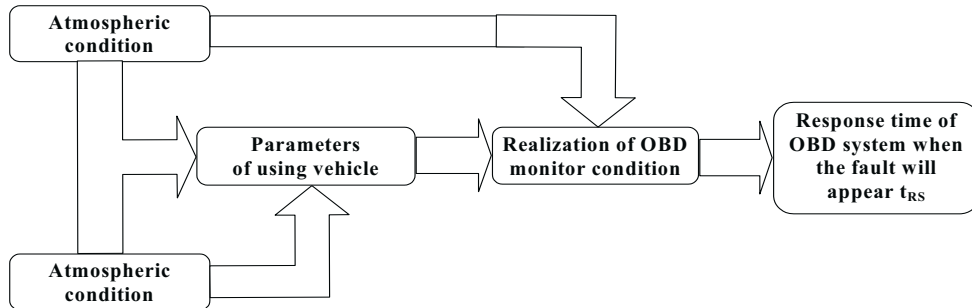

Fig. 1. Dependence among factors which have connection with response time of OBD system when the fault will appear [1, 2]

## 2. Monitor of catalytic converter efficiency

The catalyst efficiency monitors currently used in the OBD II systems use some information supplied by signals generated by two oxygen sensors which are located in the stream of exhaust gas before and after the catalyst (these sensors will be hereafter called PK and ZK respectively in relation to the sensors before and after the catalyst).

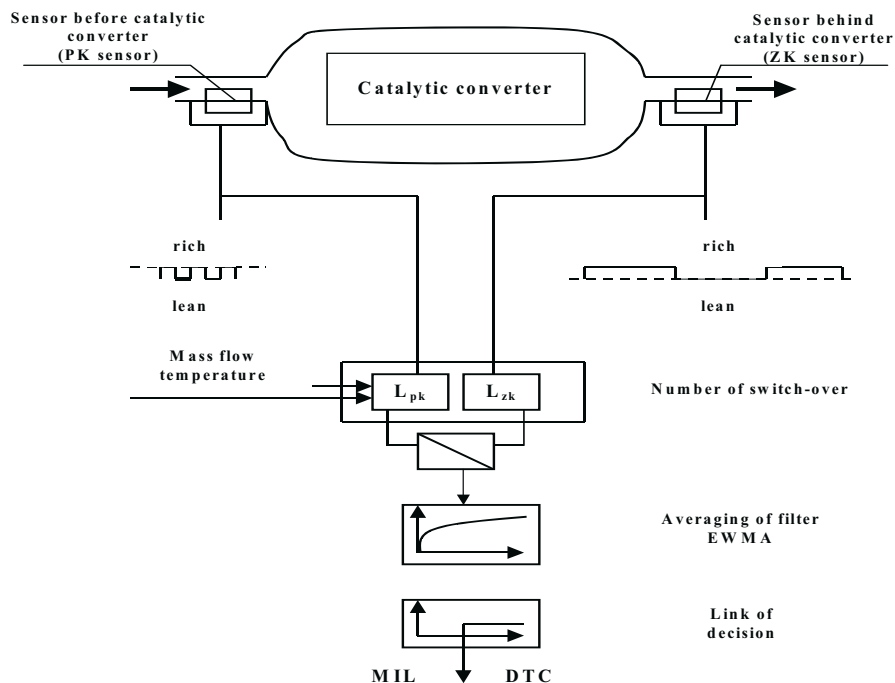

Fig. 2. Monitor of catalytic converter efficiency [3]

This concept is based on the following solutions, namely: When the catalyst is efficient the oscillations of the AFR mixture before the catalyst (as measured by the oxygen sensor PK) are attenuated in the catalyst and the AFR (Air Fuel Ratio) signal after the catalyst (as measured by

the oxygen sensor ZK) becomes stable - the reduction of both amplitude and frequency of the signal oscillations can be observed. In case of the catalyst failure the AFR signal read out from the sensor located after the catalyst is no more subject to the significant change and its characteristic is similar to the one of a signal coming from the sensor located before the catalyst.

At the large oxygen capacity the ZK sensor is being significantly more rarely switched than the PK one and when counting the number of switching between both sensors per longer time interval the ratio of such switching is close zero. The ability of storing the oxygen consumed by the catalyst is low thus the mean frequency of switching for the ZK sensor (for closed loop) tends to the frequency of switching for the sensor before the catalyst. The ratio of switching numbers recorded in the longer time interval is close. The commencement of the efficiency evaluation procedure, for which the ratio of switching numbers is the main diagnostic parameter, occurs after the supply system entry into the work area of the closed loop of the engine and catalyst lower limit temperatures. This procedure is based on counting the switching number of the PK sensor during the operation of the engine at different loads determined by the mass air flow values. In practical applications as many as up to 9 separate areas of counting the switching number for the PK sensor can be used (mostly, however, three areas are being used). The number of switching of the ZK sensor is calculated totally for an air flow area as a whole. The monitor is considered completed if a number of switching of the PK sensor for a given working area has been recorded. Then the obtained number of switching for the PK sensor shall be divided by the total number of switching for the PK sensor what in the effect will give the estimate of the main diagnostic parameter determining the oxygen capacity.

After a cold engine start the catalyst efficiency monitor starts after about 330 s and lasts for about 900 s. In this time interval about 200 to 600 switching of the ZK sensor are accumulated.

The above outlines the way how the control system simulates artificially the vehicle emission control system by changing the mixture composition from rich to lean and inversely. The response of both sensors (PK and ZK) to this simulation is analysed as a function of delays between the times of switching for those sensors and the recorded number of switching.

### **3. Monitoring of aftertreatment systems**

The carbon dioxide and hydrocarbons emission from the modern self-ignition engines reaches the values near the ones being recorded for the spark ignition engines equipped with the three-function catalyst. Further reduction of the toxic substances from the engines of this type does not present any significant problems. However, the problem is how to limit the nitrogen oxides and particulate matter emission. The compression ignition engines CI are equipped with the exhaust gas catalyst of Oxicat (*Oxidation Catalyst*) and the DeNO<sub>x</sub> types and with the particulate matter filter. It happens that the DeNO<sub>x</sub> catalyst becomes gradually poisoned by sulphur which is contained in fuel whereas the filter is being filled up with the particulate matter and gets plugged. For ensuring the effective operation of these units their efficiency must be kept under constant monitoring so that it could be possible to start the regeneration procedure immediately, if needed.

The methods developed for the catalyst diagnosis can be divided into three groups [4]:

- methods using the measurement of the exhaust gas temperature,
- methods using the oxygen concentration sensors (quantitative detection of the emitted heat),
- methods using the toxic substance concentration sensors (direct detection of the catalyst operation).

The arrangement of the individual elements of the diagnostic systems belonging to the groups discussed above is presented in Fig. 3.

The paper [5] presents some opinion that the use of the HC conventional sensors for monitoring the catalyst is unreasonable as the signal value is not satisfactory sensitive to the catalyst efficiency (especially in case of its high temperature operation). However, in accordance

with [6], the use of the CO sensors with their simple signal processing algorithm seems to be reasonable when used for the catalyst efficiency evaluation.

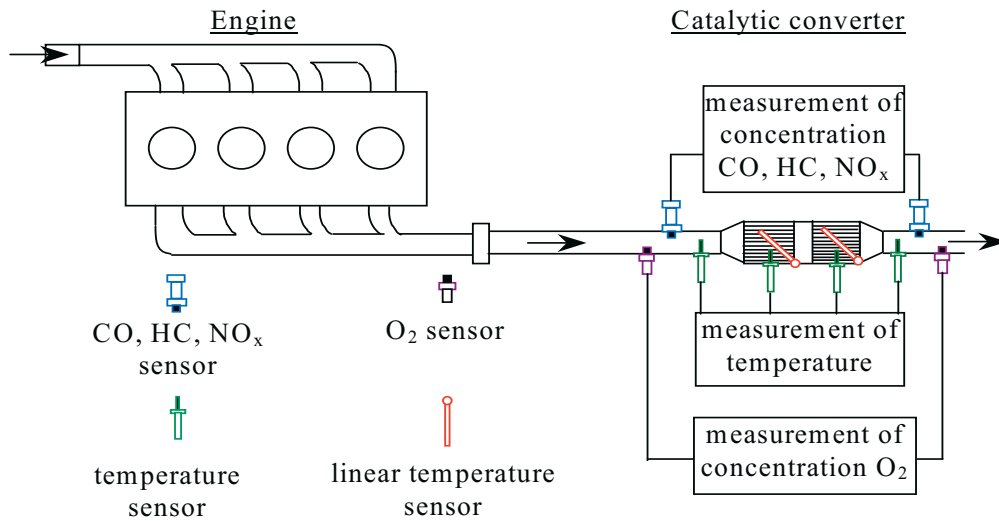

Fig. 3. Diagram of location of on board diagnostic elements in exhaust pipe [4]

The NO<sub>x</sub> sensors are more and more often installed in the on board diagnostic systems OBD II/EOBD. The measurement of concentration of CO, HC and NO<sub>x</sub> in exhaust gas, shown in Fig. 4, presents such an exemplary solution. The analyser discussed below performs the simultaneous measurements of concentration of hydrocarbons, carbon oxides and nitrogen oxides. The first valve collects exhaust gas at the catalyst input, the second one collects it at the catalyst output. However, the third valve is used for taking the samples of exhaust gas that have already flown in through the first and second valves and for delivering them to the analyser. The measurement of content of the toxic compounds in exhaust gas makes possible to determine the state of the catalyst.

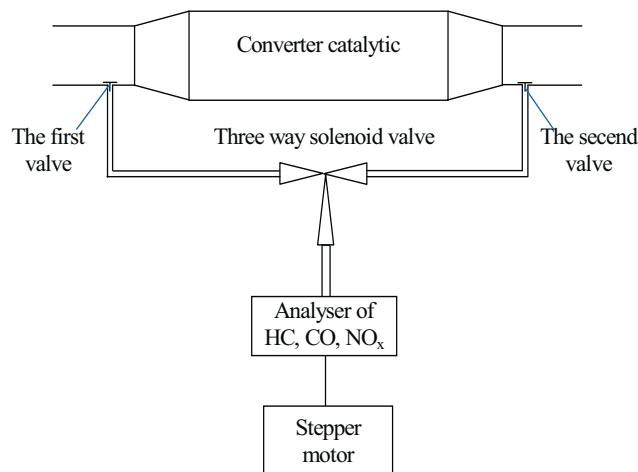

Fig. 4. Diagram of measurement system CO, HC and NO<sub>x</sub> in exhaust gases [4]

The amount of NO<sub>x</sub> emitted from the engine is conditioned by many factors, starting from the environmental conditions (humidity, ambient temperature and pressure), through the composition and type of fuel and ending on the engine state. Up to now all undertaken actions, both to develop any mathematical description of the NO<sub>x</sub> emission from the compression ignition engines and to determine the amount of NO<sub>x</sub> emission during the control survey of the engine, failed.

In case of the exhaust gas emission from the compression ignition engines the amount of

molecular oxygen is about 20 per cent. This situation calls for a solution which could radically extend the range of the oxygen concentration measurement. The solution presented in the paper consists in completing the Nerst's classical cell with an electronic segment which forces an outflow of the oxygen ions. The reference electrode of the Nerst's cell is located in the atmosphere of air. The individual constituents of exhaust gas diffuse through the diffusion barrier into the space in which some state of the thermodynamic balance is attained. The voltage connected to the porous electrodes, which are formed directly on the electrolyte, forces some cathode-to-anode flow of the oxygen ions. The flow of such a type is called „an oxygen pump” [6].

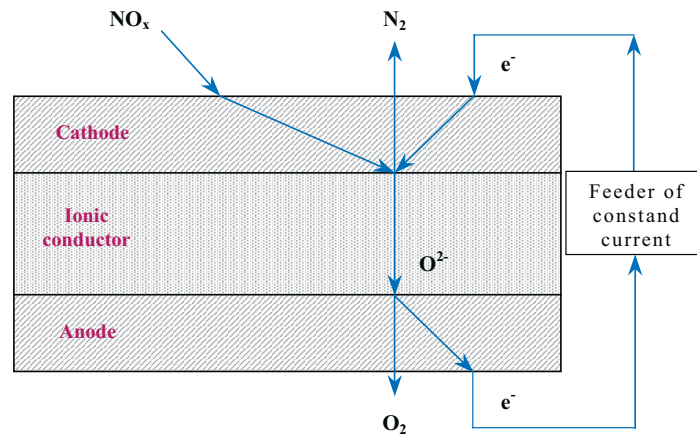

Fig. 5. Diagram of mechanism transportation gas across constant electrolyte [6, 8, 9]

The flow of ions in such „a pump” is proportional to the difference of the oxygen concentrations existing on both sides of the pump. The task for this electronic control unit is to set such a value of the pump flow that the exhaust gas composition in the diffusion space corresponds to the stoichiometric fuel-oxygen mixture. The increase of the applied voltage (for the specified temperature, electrolyte type and electrode distance) intensifies the current in the cell to some value limited by the oxygen concentration.

A method of the nitrogen oxides measurement using the zirconium dioxide-based sensor was developed in the nineties years of the last century. The measuring device consists of a sensor and a recording unit. Exhaust gas gets into the sensor (Fig. 5.) where in turn in its two diffusion chambers the exhaust gas oxygen content is being removed. The chambers are preheated and coated by zirconium dioxide-based electrodes. The gas, in which 0.01 ppm of  $O_2$  is being left, gets into the measuring chamber where the measuring electrode made of rhodium is placed [10, 11].

The scheme of the operation principle of the  $NO_x$  sensor is presented in Fig. 6. This sensor is based on six layers of zirconium dioxide. A space for measuring the exhaust gas concentration is on the second layer, the reference space with an access to the air is on the fourth layer whereas the space with an internal heater installed for controlling the temperature is provided between the fourth layer and the sixth one [6, 9-13].

The operation principle of the  $NO_x$  sensor is presented in Fig. 6. Exhaust gas entering from the left side comes through the space (1) in which the voltage to be applied is properly selected for the first thin layer made in  $ZrO_2$  (operating as a pump which removes the exhaust gas molecular oxygen  $O_2$  content and reduces  $NO_2$  to  $N_2$ . The performance of the oxygen pump is controlled in order to maintain the concentration of  $O_2$  in the space (1) before using the reference electrode to prevent the  $NO$  decomposition). Then the exhaust gas passes from the space (1) to the space (2) and  $NO$  is transported in an electrolytic way from the third thin layer of  $ZrO_2$  in a form of electrolyte for measuring a current of flow. Thereby from  $NO$  remains only  $O_2$  which is subject to the electrolysis in the space (2) and a current of flow is an equivalent of the  $NO$  amount.

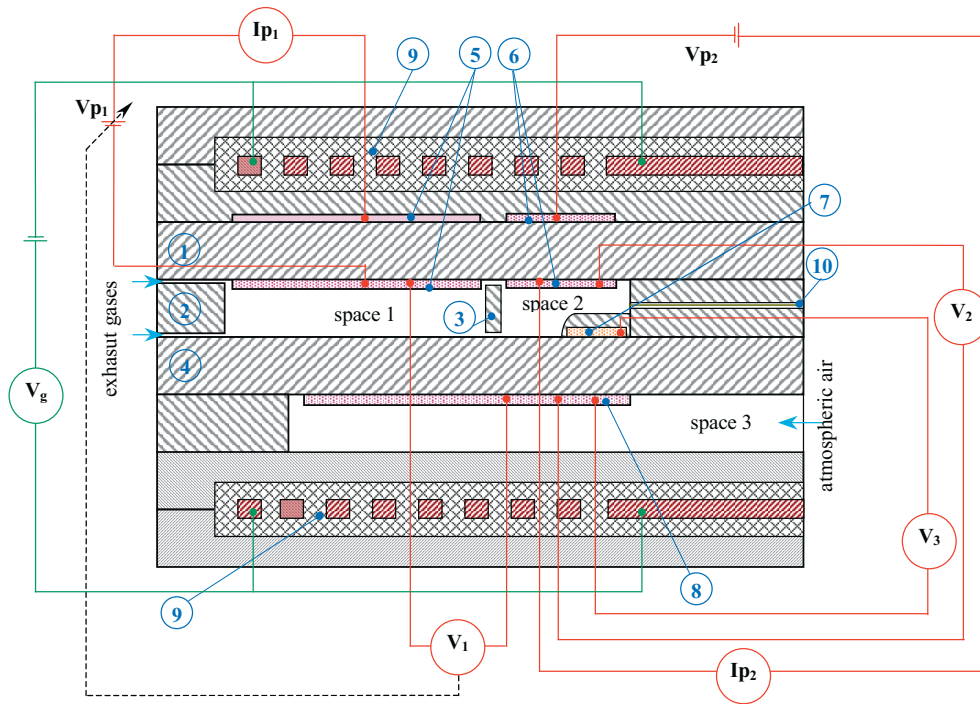

Fig. 6. Operation principle of  $\text{NO}_x$  sensor: 1 - ionic conductor made (YSZ), 2, 3 - diffusivity of ceramic separator, 4 - ionic conductor (YSZ), 5 - platinum electrodes, 6 - platinum electrode, 7 - platinum-rhodium electrode, 8 - platinum electrode 9 - heater, 10 - pressure valve [6, 9-13]

A correct operation of a sensor (its repeatability) depends on [6]:

- a plate thickness,
- the area of electrodes,
- an electrode porosity,
- a diffusion insert porosity,
- the area of platonic electrodes located in area on a plate,
- a diffusion insert porosity,
- a plate thickness.

The Pd-Ag and Pd-Ni alloys usually used in the laboratory studies cannot be used in normal engine operation conditions due to the presence of sulphur in the atmosphere and some susceptibility of their surfaces to degradation. At the normal operation of the compression ignition engine the adsorbed sulphur does not only delay the action of the catalyst bed during a cold start and idle running but also affects the indications of the sensors from these engine operation stages.

Metals used in the  $\text{NO}_x$  sensors can be ranked in relation to their highest susceptibility to the sulphur corrosion in a following way:  $\text{Ag} > \text{Pd} = \text{Ru} > \text{Rh} = \text{Pt}$ .

#### Tested station

The engine research work presented in this paper was carried out in the laboratory of the Institute of Combustion Engines and Transport at Poznań University of Technology. For the research needs an exhaust system of the tested engine was adequately adapted. The engine test stand consisted of the following elements [4]:

- 4CT90 compression-ignition engine manufactured by WSW Andoria,
- AMX-210/100 eddy-current brake with water cooling,
- reducing catalytic converter equipped with carriers of 200 cpsi density,
- HORIBA MEXA 7100 exhaust emission analyser,
- temperature sensors,
- pressure sensor.

For determining the efficiency of the applied catalyst, and NO<sub>x</sub> probe as well, on the adapted test stand under the engine test bench conditions (Fig. 7), some preliminary tests were carried out according to the obligatory ESC (European Stationary Cycle) test.

A special catalytic converter equipped with carriers of 200 cpsi density was built for the test needs. It consists of five blocks with dimensions of 125×50 mm. The catalyst casing enables performing the tests for a variable number of catalytic blocks and taking the measurements behind each block.

A chemical composition of the catalytic converters was developed in the Institute of Internal Combustion Engines at Poznań University of Technology in cooperation with the Department of Inorganic Chemistry at AGH University of Science and Technology in Kraków. The catalytic layers were produced by means of the USPD (Ultra Spray Pyrolysis Deposition) and sol-gel methods for CeO<sub>2</sub>-ZrO<sub>2</sub>/PtPd and CeO<sub>2</sub>-ZrO<sub>2</sub>/PtRu components [6].

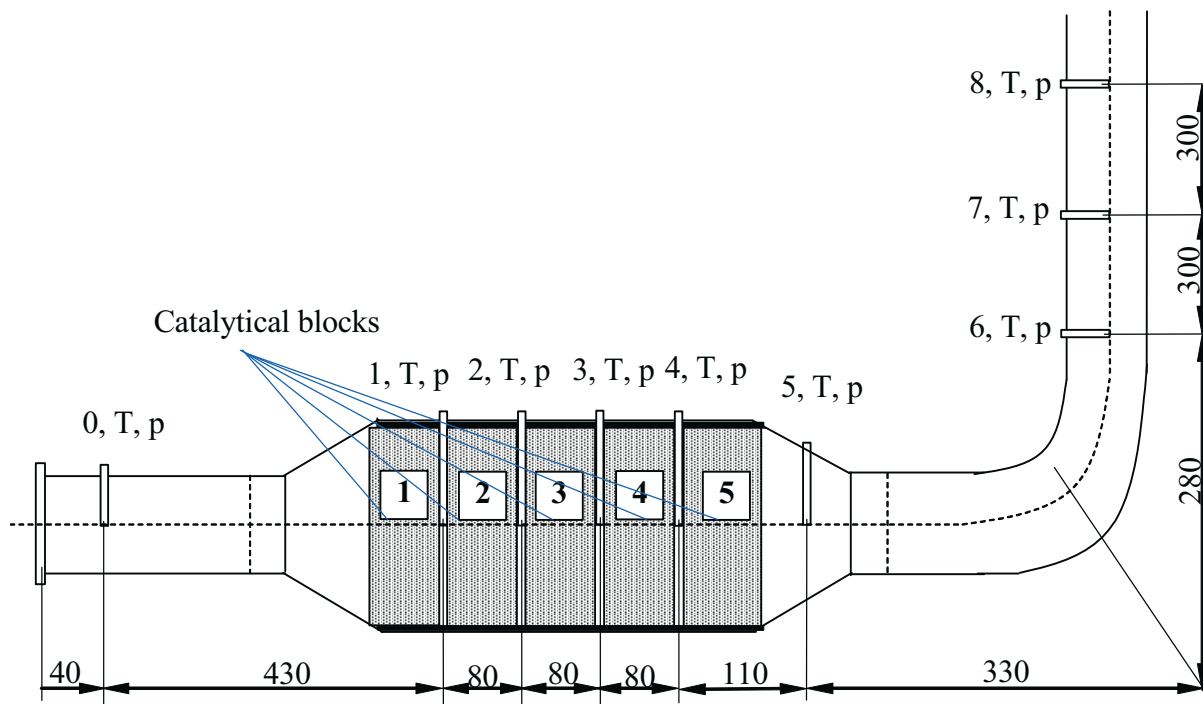

Fig. 7. Diagram of modification exhaust pipe with installed catalytically converter in test bed and present of measurement points [6]; 0-8 - measurement points:(T) - temperature, (p) - pressure

#### 4. Analyses of temperature dissolution in exhaust pipe

The temperature is a basic parameter affecting the ability of generating voltage signals by the sensors produced in the „sensor to sensor” technology. Owing to the design of sensors and the constructional materials used for the execution of electrodes in the individual areas, as shown in papers [6, 14], it was necessary to provide an additional reheating to reach the temperatures which enable starting the oxygen pumps. Taking into consideration the operating parameters of the engine examined on the engine test bed the exhaust gas temperatures during the realization of the ESC test could reach the range in which generating the diagnostic signals by the sensors was possible. Overheating the measuring probe of a sensor caused by too high temperatures of exhaust gas while supplying a system of heaters with an external voltage can result in a degradation of electrodes. Therefore the developed laboratory system requires a manual selection of the voltage for supplying a sensor in a way eliminating a risk of exceeding the threshold voltage value for given engine operating conditions. To complete the gathered knowledge on the possibilities of

delivering the supply voltage depending on the temperature in the exhaust engine system an analysis of the temperature distribution was carried out in the measuring points of the exhaust system, provided for the NO<sub>x</sub> sensors [6].

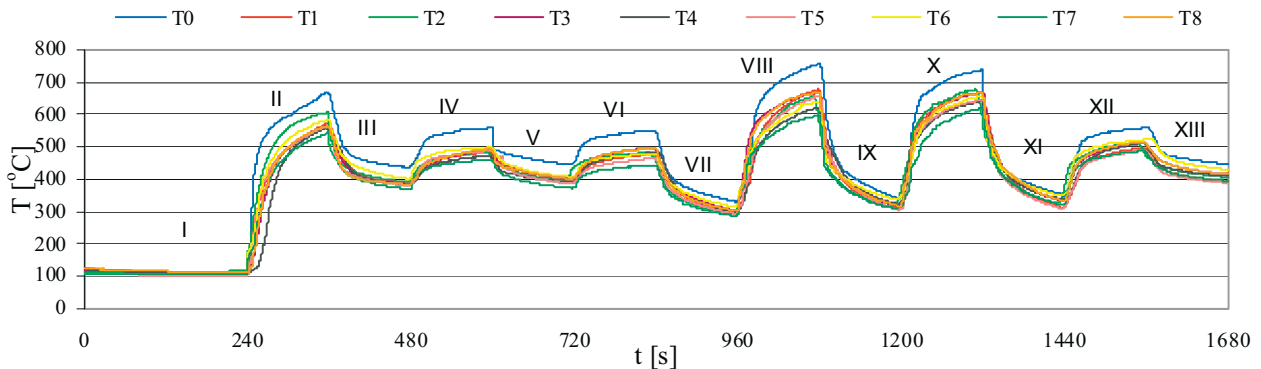

Fig. 8. Distribution of temperature in measurement point T0-T8 exhaust pipe of testing engine without catalytically converter during realization ESC test [6]

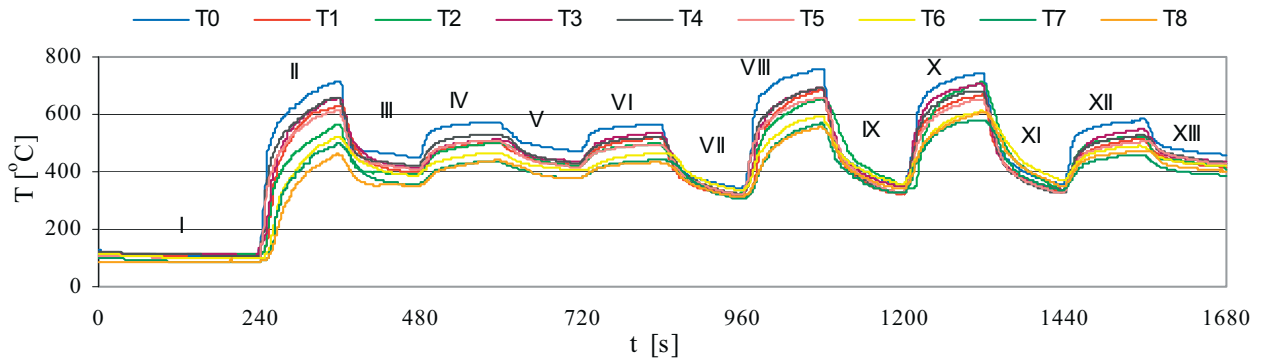

Fig. 9. Distribution of temperature in measurement point T0-T8 exhaust pipe of testing engine with 200 cpsi catalytically converter during realization ESC test [6]

The performed analysis indicates that with regard to the exhaust gas temperatures the phases II, VIII and X are most critical. It concerns both temperatures measured without and with the catalyst provided. In case of phase II the highest temperature of 710°C was reached at the T0 point of the exhaust system equipped with a catalyst with a carrier of 200 cpsi density.

In case of phases VIII and X the exhaust gas temperature were reaching the values ranging from 737°C to 759°C. These are temperatures at which the sensors, owing to their design and constructional materials for electrodes, are able to generate voltage signals without necessity of reheating. For all other test phases the highest temperatures were reached at the T0 point and the recorded temperatures were not exceeding the value of 600°C.

This analysis indicates that in case of phases VIII and X, during a realization of the engine test bed examinations, the applied sensors will be most sensitive to the controlled supply voltage value. The obtained temperature distribution suggests that for these phases the sensor reactions should be fastest as the optimum sensor temperatures can be reached without necessity of reheating. However, the above applies to the sensor installed at T0.

## 5. Analyses of pressure dissolution in exhaust pipe

The rate of chemical reactions is a function of the reactive exhaust gas components, exhaust gas temperature, type of the applied catalyst and pressure. For reactions proceeding in a gaseous



phase the concentrations and pressures are interdependent. However, the pressure can independently affect the reaction rate values, thereby the response times of the sensor in the considered system. In order to find the importance of these variables the experiments should be carry out in a way which makes possible a simultaneous change of the smallest number of parameters. It is impossible to perform such experiments in case of examination being realized under the engine test bed conditions. For this reason the importance of pressure is limited to its effect on the sensor response time with regard to the exchange of exhaust gas present in the sensor's probe.

The pressure in the exhaust system affects the intensity of the gas exchange in a sensor by affecting the pressure present in a measuring probe, as shown in papers [6, 14]. When an increase in pressure in a measuring area is faster the speed of the gas exchange in the individual regions of the NO<sub>x</sub> increases and thereby a frequency of the voltage signals should be greater.

With reference to the classic catalyst the engine exhaust system pressure results in a number of the molecules adsorbed within a catalytic layer. Regarding it to the sensor conditions a number of the collisions of oxygen molecules with the electrode *pt* should be also higher what can directly result in the sensor response time value.

In the phase i of the test, in which the engine was operating at idling speed, the average overpressure in the exhaust system without the catalyst was of  $0.03 \cdot 10^{-4}$  pa (Fig. 10). In case of the exhaust system equipped with the catalysts with the 200 cpsi carriers such same overpressure values of  $0.03 \cdot 10^{-4}$  pa were recorded. From the considered research point of view such values do not allow to get information necessary for the realisation of the next assumed examination.

Analysing a distribution of pressure in the exhaust system without the catalyst it can be found that for all phases of the test the pressure differences between the p0–p5 points are small (Fig. 10). In points p6–p8 which are distant from the point p5 by 60 cm the pressure values are also similar. In every phase, depending on the overpressure values, the measuring points can be separated into two groups of points p0–p5 and p6–p8. In points p6–p8 the overpressure values in every phase are smaller what results from their greater distance from the exhaust collector. The differences in the overpressure values measured in the measuring points of the individual groups can be explained by the pressure fluctuation in the engine exhaust system and an indication error of the applied pressure measuring sensors.

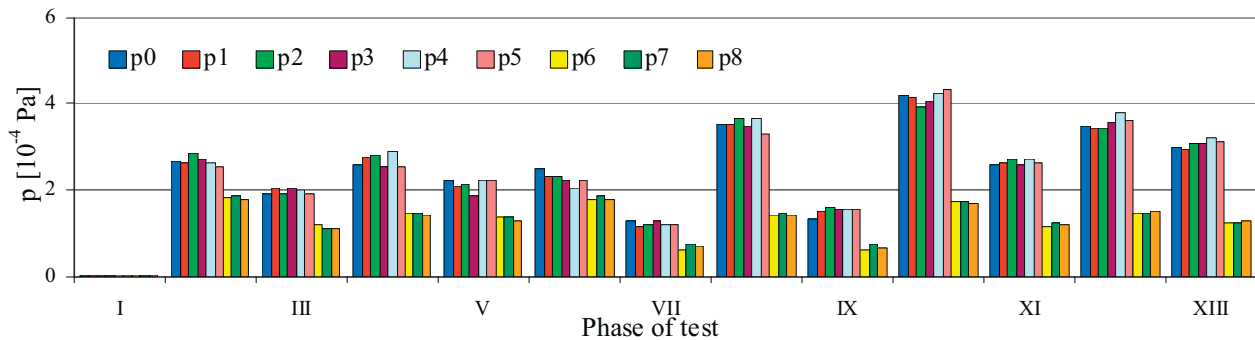

Fig. 10. Distribution of pressure in measurement point p0-p8 exhaust pipe of testing engine without catalytically converter during realization ESC test [6]

As the distance from the exhaust collector increases the pressure value decreases. In case of measuring points before (p0), in (p1 - p4) and just after the catalysts (p5), the differences in the overpressure values are caused by the exhaust gas flow resistance in the individual catalytic blocks. For every test phase in points distant from the catalyst (p6 - p8) the pressure values are much lower and continue their falling tendency depending on the distance in relation to the exhaust collector.

In case of the catalyst the highest overpressure values were recorded for the phase x at the

point p0 and they were of  $6.3 \cdot 10^{-4}$  pa for the catalyst equipped with the 200 cpsi carrier.

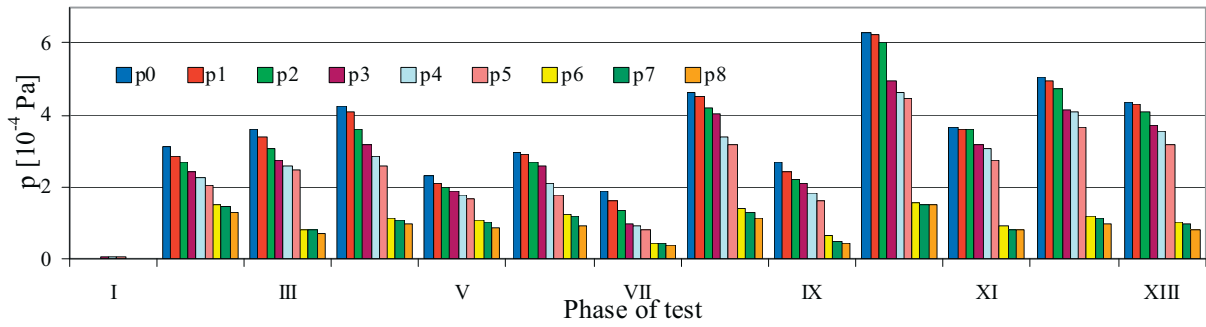

Fig. 11. Distribution of temperature in measurement point T0-T8 exhaust pipe of testing engine with 200 cpsi catalytically converter during realization ESC test [6]

### 6. Analyses of tested catalytic converter with 200 cpsi

In order to determine the effectiveness of the applied catalytic converter for the reduction of the NO<sub>x</sub> emission according to the obligatory official certification test ESC some preliminary examinations of its efficiency under the engine test bend conditions were performed. Taking the operation nature (character) into consideration the NO<sub>x</sub> emission in each phase of the test was analysed [6].

To determine the reduction in the NO<sub>x</sub> emission the emission measurements were taken after each catalytic block. The presented results are referred to the NO<sub>x</sub> concentration values before the catalytic converter. The efficiency for the individual catalytic blocks was determined from the relation:

$$k_r = \frac{C_p - C_z}{C_p} \cdot 100 [\%] \tag{1}$$

where:

- C<sub>p</sub> - concentration NO<sub>x</sub> before catalytic converter,
- C<sub>z</sub> - concentration NO<sub>x</sub> after catalytic converter.

Due to the diversified parameters characterising the catalytic converters, which are being built with the use of the catalytic carriers with different cell densities, the examinations were performed for the catalytic blocks based on the carriers with a cell density typical for the compression-ignition engines of 200 cpsi (Fig. 12). The application of the catalytic carriers with higher cell densities

was considered inadvisable because of a high resistance of flow of exhaust gases intensified by the PM emission.



Fig. 12. Metallic enclosure of tested of catalytic converter [6]

The operation performance of the catalytic converter with the 200 cpsi carrier is similar in each phase of the test.

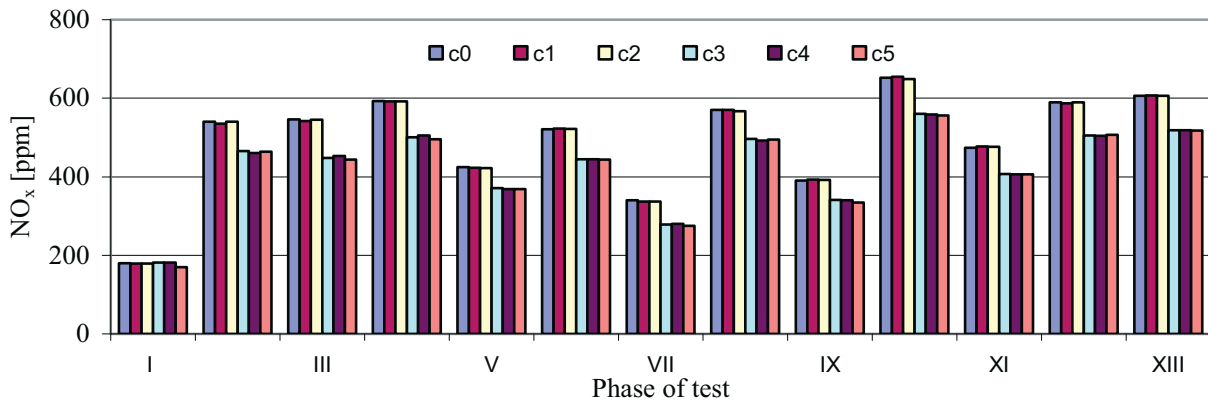

Fig. 13. Value of NO<sub>x</sub> concentration during ESC test of catalytically converter with 200 cpsi [6]

In phases II-XIII the catalytic converter was characterized by an effectiveness of the reduction in the NO<sub>x</sub> emission of 15%. The analysis of the measuring points shows that from the point c3 on the reduction in the NO<sub>x</sub> emission level was constant. That means that the catalytic reactor volume is sufficient with reference to the assumed amount of the active layer deposited on each catalytic block. The ratio of that volume to the engine displacement volume was 0.76. The analysis of the bibliographic data shows that this ratio values are in the 0.75-1.3 range.

The emission measurements in points c6–c8 are considered close to the emission measured in the point c5. For the discussed points the difference in the NO<sub>x</sub> concentration was at the indication error level of the measuring exhaust gas analyser.

The performed analysis shows that the catalytic converter with the 200 cpsi carrier allows obtaining a satisfactory difference in the voltage signals basing on the NO<sub>x</sub> concentration after the third catalytic block. However, it should be noted that the obtained effectiveness of the catalytic converter for the NO<sub>x</sub> reduction is unsatisfactory. The average percentage effectiveness of the discussed catalytic converter in the measuring point c5 was 14%.

Tab. 1. Efficiency of limit NO<sub>x</sub> concentration [%] behind ever catalytically blocks in light of concentration before catalytically converter (200 cpsi) (part I) [6]

| No phase | I    | II   | III  | IV   | V  | VI  | VII | VIII | IX  | X   | XI  | XII | XIII |
|----------|------|------|------|------|----|-----|-----|------|-----|-----|-----|-----|------|
| Point c1 | 0.3  | 0.8  | 0.1  | -0.3 | 2  | 0.3 | -1  | 1    | 0.3 | -10 | 0.3 | 10  | 0.3  |
| Point c2 | 0.4  | -0.1 | -0.5 | -0.3 | 2  | 0.4 | -1  | 1    | 0.4 | -9  | 0.4 | 10  | 0.4  |
| Point c3 | -0.8 | 13   | 17   | 15   | 14 | 15  | 16  | 14   | 13  | 5   | 15  | 23  | 14   |
| Point c4 | -0.8 | 14   | 16   | 14   | 15 | 15  | 16  | 14   | 13  | 6   | 15  | 23  | 14   |
| Point c5 | 5    | 14   | 18   | 16   | 15 | 15  | 17  | 14   | 15  | 6   | 15  | 22  | 15   |

## 7. Conclusions

On the basis of the performed examinations and obtained test results the following conclusions can be drawn:

1. The analysis of the NO<sub>x</sub> concentrations in exhaust gas from the compression-ignition engine

- can be based on the indications of the voltage probes with the modified electrodes of the oxygen pump,
2. The application of the reduction conditions in the voltage probes using the nitrogen oxides reduction by the electro-catalytic way depends on the exhaust gas parameters, the values of which change depending on the rotational crankshaft speed and engine load. For this reason obtaining the diagnostic signal for the whole engine operation range is impossible. The control of the correctness of the catalyst operation regarding the nitrogen oxides reduction can be realised for the defined operating parameters of the tested engine,
  3. For phases VIII and X of the ESC test the reheating the test probe installed before the catalyst was unnecessary owing to the high exhaust gas temperature (737–759°C).

## References

- [1] Birnbaum, R. T., Truglia, J., *Getting to know OBD II, Manufactured and United States*; Ralph Birnbaum and Jerry „G”, Truglia 2001.
- [2] Birnbaum, R. T., Truglia, J., *OBD II diagnostic strategies*, Ralph Birnbaum and Jerry „G” Truglia 2002.
- [3] Merkisz, J., Rychter, M., *Basic proceeding of diagnosis and strategy of decision on OBD II system*, Hiroshima, Japan, AVEC 2002.
- [4] Ambrozik, A., Kruczyński, S. W., Łaczyński, J., *Metody monitoringu trójfunkcyjnych reaktorów katalitycznych spalin*, *Jurnal of KONES, Internal Combustion Engines*, Vol. 7, No. 1-2, 2000.
- [5] Schenk, C., McDonlads, J., Laroo, C., *High-efficiency NOx and PM exhaust emission control or heavy duty on - highway diesel engines - part II*, SAE 2001-01-3619.
- [6] Rychter, M., *Monitoring of compression ignition engine with OBD system on basis of exhaust emission in light of ecological manageability of engine*, Ph.D. dissertation, Poznań University of Technology, Poznań 2004.
- [7] Carters, S., Baerts, C., Knaus, E., *High quality temperature sensors as the key to EURO IV*, *MTZ* 6 (62)/2001.
- [8] Kato, N., Hamada, Y., Kurachi, H., *Performance of thick film NOx sensor on diesel and gasoline engines*, *Electronic Engine Controls*, 1997.
- [9] Kato, N., Hamada, Y., Kurachi, H., *Thick film ZrO<sub>2</sub> NOx sensor for the measurement of low NOx concentration*, *Electronic Engine Controls*, 1998.
- [10] Coillard, V., Jones, W., Lucat, C., Menil, F., *Etat de l'art des capteurs de monoxide d'azote dans les gaz d'leccapement de moteurs a melange pauvre*, *Ingeniers de l'Automobile* 5/1999, pp. 46-58.
- [11] [www.wsm.gdynia.pl](http://www.wsm.gdynia.pl).
- [12] Rychter, M., *Using ionic conducter in building of sensors to measurement of components of exhaust gases in order to monitoring of catalytic converter in ci engine in light of OBDII/EObD system*, *Kongres PTNSS, 25-28.09.2005, Szczyrk, Poland* 2005.
- [13] Kobayashi, N., Naito, O., Yamashita, A., Setoguchi, T., Murase, T., *Development of simultaneous NOx/NH<sub>3</sub> sensor in exhaust gas*, *Mitsubishi Heavy Industries, Ltd. Technical Review* Vol. 38 No. 3, October 2001.
- [14] Rychter, M., *Analysis of conditions in exhaust pipe in light of application measurement probe to determine of NO<sub>x</sub> concentration*, *Transport Samochodowy* 1/2006, pp. 53–73, 2006.

## Abbreviations

|     |                  |
|-----|------------------|
| AFR | Air Fuel Ratio,  |
| Ag  | gold,            |
| CO  | carbon monoxide, |

|                   |                                    |
|-------------------|------------------------------------|
| DeNO <sub>x</sub> | Decrease NO <sub>x</sub> ,         |
| EOBD              | European On-Board Diagnostic,      |
| ESC               | European Stationary Cycle,         |
| HC                | hydrocarbon,                       |
| N <sub>2</sub>    | nitrogen,                          |
| NO <sub>2</sub>   | nitrogen dioxide,                  |
| NO <sub>x</sub>   | nitrogen oxides,                   |
| O <sub>2</sub>    | oxygen,                            |
| OBD II            | On-Board Diagnostics II,           |
| OBD               | On-Board Diagnostic,               |
| OBDE              | On Board Diagnostic Efficiency,    |
| Oxicat            | Oxidation Catalyst,                |
| Pd                | palladium,                         |
| PK                | sensor before catalytic converter, |
| USPD              | Ultra Spray Pyrolysis Deposition,  |
| YSZ               | Yttrium Stabilization Zirconium,   |
| ZK                | sensor behind catalytic converter. |

*"The author's reward was sponsored by Society of Collective Management of Copyrights of Creators of Scientific and Technical Works KOPIPOL with registered office in Kielce with duties obtained on the ground of the art. 20 and art. 20<sup>1</sup> of law on copyrights and related rights."*

